

Random Access Machines

A random access machine (RAM) is a simple *model of computation*. Its memory consists of an unbounded sequence of registers. Each of the registers may hold an integer value.

The *control unit* of a RAM holds a *program*, i.e. a numbered list of statements. The *program counter* determines which statement is to be executed next.

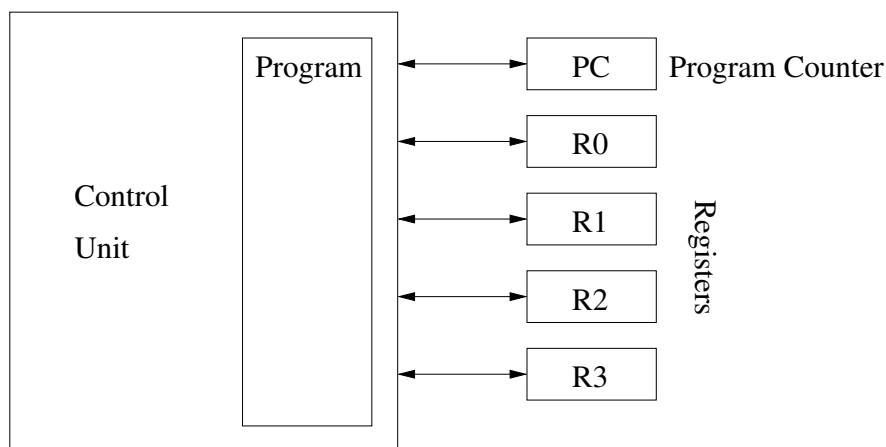

Rules for executing a RAM-program:

- in each work cycle the RAM executes one statement of the program;
- the program counter specifies the number of the statement that is to be executed;
- the program ends when the program counter takes an invalid value (i.e. there's no statement in the program that has the specified number)

To “run” a program in the RAM, we need to:

- define the program, i.e. the exact list of statements;
- define starting values for the registers (the *input*);
- define starting values for the program counter (usually, we'll start with the first statement);

Statements of a RAM

Notation:

- $\langle Ri \rangle \hat{=} \text{the integer stored in the } i\text{-th register}$
 $\langle Ri \rangle := x \hat{=} \text{let integer } x \text{ be the content of the } i\text{-th register}$

List of Statements:

Statement	Effect on registers	Program Counter
$Ri \leftarrow Rj$	$\langle Ri \rangle := \langle Rj \rangle$	$\langle PC \rangle := \langle PC \rangle + 1$
$Ri \leftarrow RRj$	$\langle Ri \rangle := \langle R\langle Rj \rangle \rangle$	$\langle PC \rangle := \langle PC \rangle + 1$
$RRi \leftarrow Rj$	$\langle R\langle Ri \rangle \rangle := \langle Rj \rangle$	$\langle PC \rangle := \langle PC \rangle + 1$
$Ri \leftarrow k$	$\langle Ri \rangle := k$	$\langle PC \rangle := \langle PC \rangle + 1$
$Ri \leftarrow Rj + Rk$	$\langle Ri \rangle := \langle Rj \rangle + \langle Rk \rangle$	$\langle PC \rangle := \langle PC \rangle + 1$
$Ri \leftarrow Rj - Rk$	$\langle Ri \rangle := \max\{0, \langle Rj \rangle - \langle Rk \rangle\}$	$\langle PC \rangle := \langle PC \rangle + 1$
GOTO m		$\langle PC \rangle := m$
IF $Ri=0$ GOTO m		$\langle PC \rangle := \begin{cases} m & \text{if } \langle Ri \rangle = 0 \\ \langle PC \rangle + 1 & \text{otherwise.} \end{cases}$
IF $Ri>0$ GOTO m		$\langle PC \rangle := \begin{cases} m & \text{if } \langle Ri \rangle > 0 \\ \langle PC \rangle + 1 & \text{otherwise.} \end{cases}$